

INNOVATIVE IDEAS. DEPENDABLE SOLUTIONS. TOTAL RELIABILITY.



# THE XEROX PHASER 7400 TONER & DRUM CARTRIDGES



DOC# 0403

By Mike Josiah and the technical staff at Summit Technologies  
– a Division of Uninet Imaging.



XEROX PHASER 7400 TONER & DRUM CARTRIDGE REMANUFACTURING INSTRUCTIONS

Page 1

USA Sales: T 800.221.3516 F 888.791.9188  
International Sales: T +1 631.590.1040 F +1 631.218.3285  
[www.summittechnologies.com](http://www.summittechnologies.com)

# Remanufacturing the Xerox Phaser 7400 Toner & Drum Cartridges



The Xerox Phaser 7400 Toner & Drum Cartridge

**T**he Xerox Phaser 7400 printers are based on a 36ppm color/40ppm monochrome, 1200 dpi engine. All versions are based on an 800MHz PowerPC chip, and come standard with either 256MB or 512MB memory (depending on the model). In all models the max is 1GB of memory. This engine uses a two cartridge system, a toner tube and a drum unit. The toner tube is very easy to remanufacture, the drum unit is a bit more complicated but also fairly easy to do. Both cartridges will be covered in these instructions.

The machines based on the Phaser 7400 engine are the:

- Phaser 7400
- Phaser 7400DN
- Phaser 7400DT
- Phaser 7400DX
- Phaser 7400DXF

These units have 4 toner tubes, 4 drum units, a separate waste toner cartridge, and transfer unit. With the exception of the black, the toner tubes come in both standard and high yield (9,000 and 18,000) yields. The black tube comes only in a 15,000 page yield. It is interesting to note that both the toner tube and the drum unit need to be reset. The toner tube uses a chip while the drum unit uses a fuse. Both need to be replaced each cycle. The toner tube chips are hidden under the cartridge identification label, while the drum unit's fuse is in an end cap.

In addition to the drum unit, the fuser assembly and transfer belts both have a fuse installed on them. When a new unit (drum transfer or fuser), is detected, the printer resets that units life counter and then blows the fuse. The counter will not show as reset until two pages have been printed. After the counter has been reset, it will count the pages printed until the maximum life has been reached for that unit.

The cartridges used in the Xerox Phaser 7400 are as follows:

106R01080	15,000 page yield Black cartridge	\$181.00 retail*
106R01150	STD yield (9,000 pages) Cyan cartridge	\$296.00 retail*
106R01151	STD yield (9,000 pages) Magenta cartridge	\$296.00 retail*
106R01152	STD yield (9,000 pages) Yellow cartridge	\$296.00 retail*
106R01077	High yield (18,000 pages) Cyan cartridge	\$437.00 retail*
106R01078	High yield (18,000 pages) Magenta cartridge	\$437.00 retail*
106R01079	High yield (18,000 pages) Yellow cartridge	\$437.00 retail*
108R00650	Black drum unit (30,000 pages)	\$188.00 retail*



108R00647	Cyan drum unit (30,000 pages)	\$188.00 retail*
108R00648	Magenta drum unit (30,000 pages)	\$188.00 retail*
108R00649	Yellow drum unit (30,000 pages)	\$188.00 retail*
106R01081	Waste toner cartridge (30,000 pages)	\$309.00 retail*

\*Retail pricing as of July 2007

The fuser assembly is rated for 100,000 pages.

It is also important to note that new OEM drum cartridges come filled with toner. When you rebuild a drum unit, it is important to include a rebuilt toner tube so that the customer gets the same value. It is possible to fill the drum unit with out a tube, but it is extremely difficult, and the possibility of dumping the toner is very high. A filled tube is a much better way to go, plus if you give them a high yield version, you can charge more and still give your customers better value.

**Figures A and B** show how the drum unit comes packaged.



Figure A



Figure B

**Figures C & D** show the tab system that keeps different color toner cartridges from accidentally being installed in the wrong drum units. The cartridges shown are for the black system.

Since this printing system is different from anything covered in the past, we will be covering the printer theory here. Cartridge and printer troubleshooting as well as how to print test pages will be covered at the end of this article.



Figure C



Figure D

### Cartridge Theory

As with most other theory sections we have done, the easiest way to follow the theory is to break it down into a series of steps or stages. But first the first 3 diagrams show in general the physical layouts of some of the more important parts.

**Figure 1** gives an overview of the printer, the toner, and drum (Imaging) units as they all relate to each other. Note that these machines are not laser printers. They are LED printers. Each color has a bank of LED's that write the image to the drum.

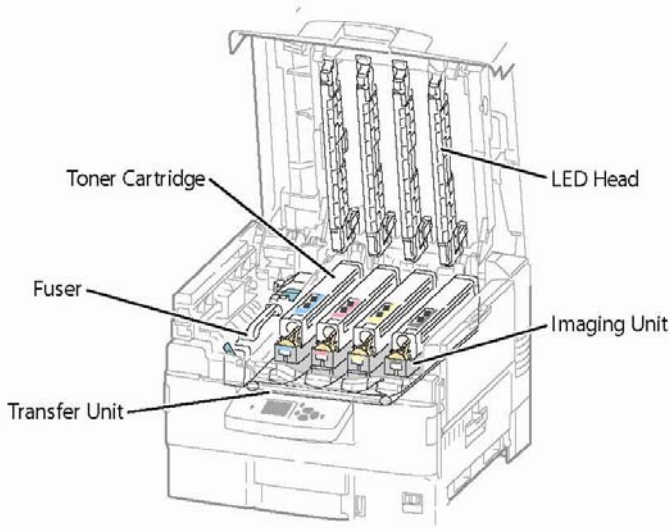

Figure 1

**Figure 2** gives a nice side view breakdown of both the drum unit and the toner tube.

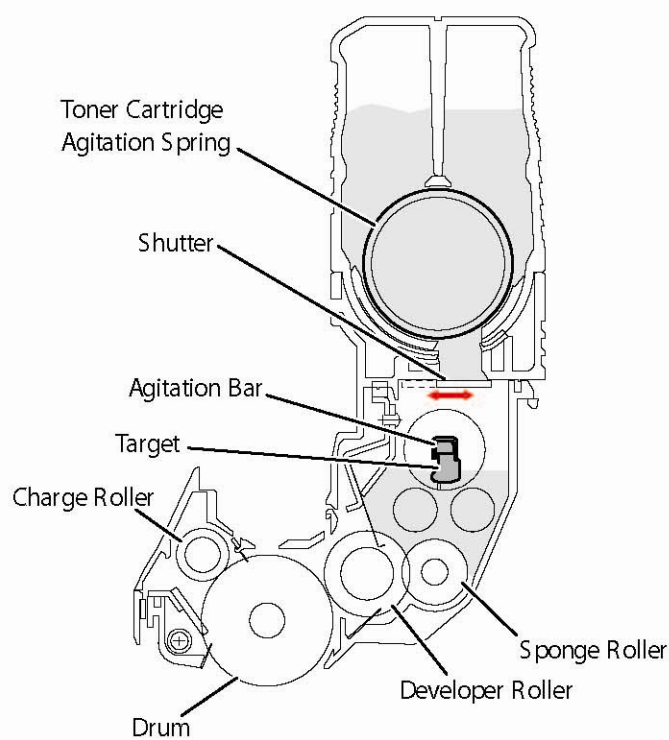

Figure 2

**Figure 3** shows the LED heads in the top cover of the printer and their covers.

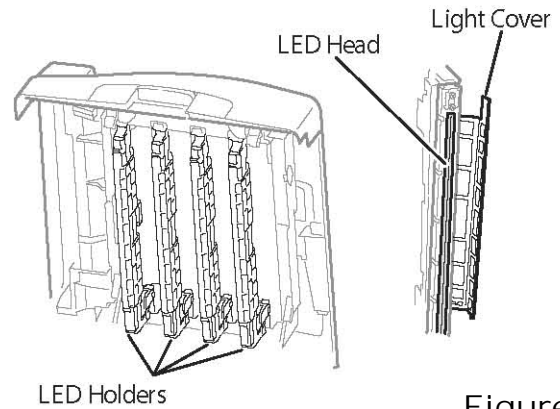

Figure 3

In the first stage the Primary Charge Roller (PCR) places a uniform negative DC voltage on the OPC drum surface. The amount of the negative DC voltage placed on the drum is controlled by the printer's intensity setting. See **Figure 4** This process occurs simultaneously for all 4 color cartridges.

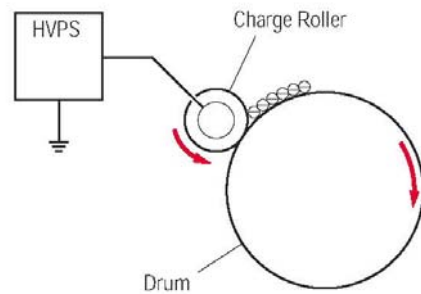
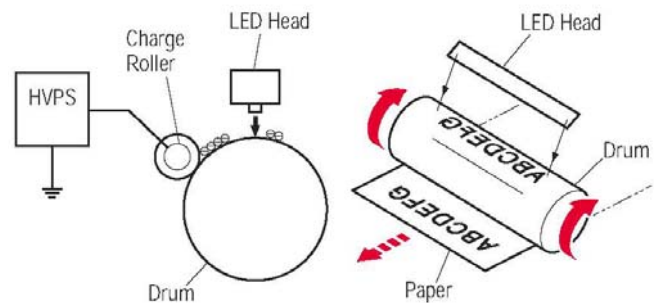

Figure 4



In the second stage, the LED head emits light directly to the negatively charged surface of the drum. LED printers do not use scanners or mirrors; the LED head

spans the width of the entire page with ????? of individual LED lamps . This light leaves a latent electrostatic image on the drum. The areas where the light did not strike the drum will retain the higher negative charge. Unlike lasers, LED heads also have the ability to change the power of the light that strikes the OPC drum. This process allows for better control of half tones. Each color cartridge has its own LED head; all four Led heads operate simultaneously. See also **Figures 4**

The third or developing stage is where the toner is developed on the drum by the developing section (or supply chamber), which contains the toner particles. The development stage is actually made up of two steps: toner charging, and the actual development. In the toner charging stage, the toner feed (sponge) roller turns inside the hopper. As the sponge feed roller brings the toner to the developer roller it also places a negative charge on the toner. This charge ensures a uniform charge on the toner. Once the toner is properly charged, the toner will coat the developer roller. The toner is also held onto the developer roller by another negative DC bias voltage. This voltage is controlled by the printer's intensity setting, and causes either more or less toner to be attracted by the developer roller. This in turn will either increase or decrease the print density. The amount of toner on the developer roller is controlled by the doctor blade, which uses pressure to keep the amount of toner on the roller constant.

As the light exposed areas of the OPC Drum approach the developer roller, the toner particles are attracted to the drum's surface due to the opposite voltage potentials of the toner, and LED light exposed areas of the OPC drum. See **Figure 5**

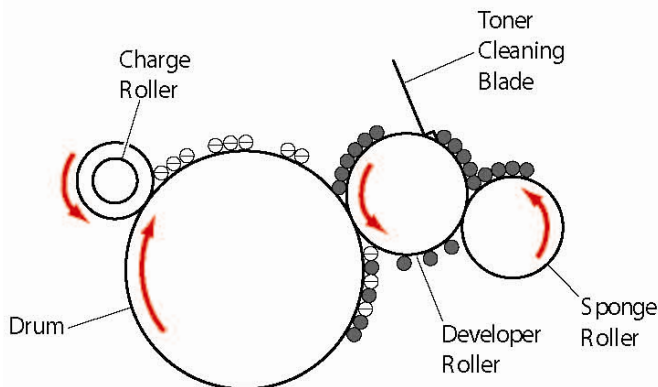

Figure 5

The fourth stage is the transfer stage. In this stage, the transfer roller (which is located directly opposite each OPC drum), places a positive DC bias charge on the

back of the transfer belt. Each toner cartridge has a separate transfer roller that is made from a conductive sponge material. At the same time, the paper is moving between the OPC drum and the transfer belt. As the paper/belt passes the transfer roller, the positive charge is picked up, and draws the negatively charged toner off the drum onto the paper. This process is repeated for each color cartridge. As the toner piles onto the paper, the positive charge on the paper weakens as the paper runs through each cartridge. For this reason, the charge is increased slightly from the transfer charging roller for each successive color. See **Figure 6**

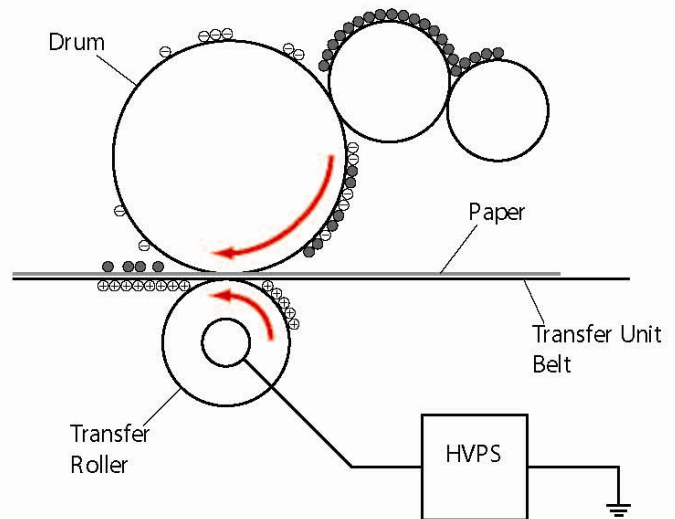

Figure 6

In the fifth stage, the image is then fused onto the paper by the fuser assembly. The fuser Assembly is comprised of the heating assembly and pressure roller. The pressure roller presses the page up into the heating assembly which then melts the toner into the paper. The heating assembly consists of a flexible sleeve with the pressure roller inside and a heat roller that sits on top of it. This system is very different from other HP or Lexmark systems. See **Figure 7**

#### Drum and Transfer Belt Cleaning:

The drum and transfer belt are both cleaned after the image is transferred to the paper. Unlike most of the more complicated HP systems, these machines have just a simple wiper blade/auger system that removes the old toner and places it into the waste cartridge. Both the drum unit and the transfer belt have separate cleaning systems, but all the waste toner from both units goes to the same separate waste unit. See **Fig. 8**

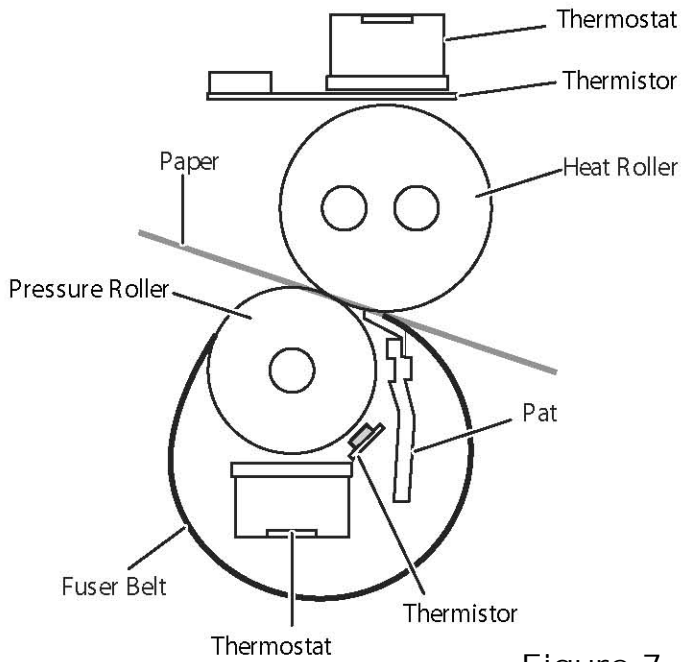

Figure 7

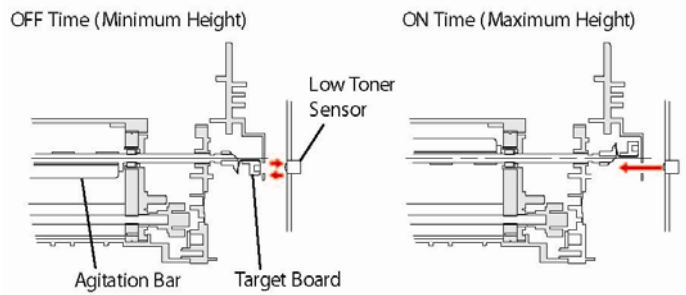

Figure 9

After checking the toner level 3 times, and the toner level state remains low, the toner supply agitator rotates and brings more toner into the hopper. Once the toner level returns to high, the agitator stops rotating.

After the toner low state is detected 20 times, the printer considers the toner tube empty. See **Figure 10**.

Registration? Copy test from 4700

Automatic Density control

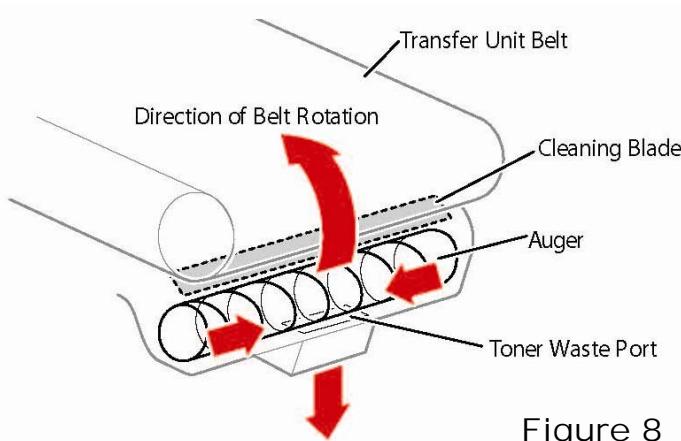

Figure 8

**Toner Level Detection:**

Each drum unit contains an Agitation gear and Agitation bar. The Agitation bar moves the toner to the area above the developer roller. Located at the end of the Agitator bar is the toner low sensor target. Located in the printer, the toner low sensor is an optical sensor that monitors the amount of light reflected back from the target. As the toner level drops, the period of time that the agitation bar remains at its highest point is reduced. This time change signals toner level changes. There are three levels of toner status; OK, Low and empty. When the empty state has been reached, the printer terminates the current job (at the end of the current page), and will not accept any new jobs. See **Figure 9**

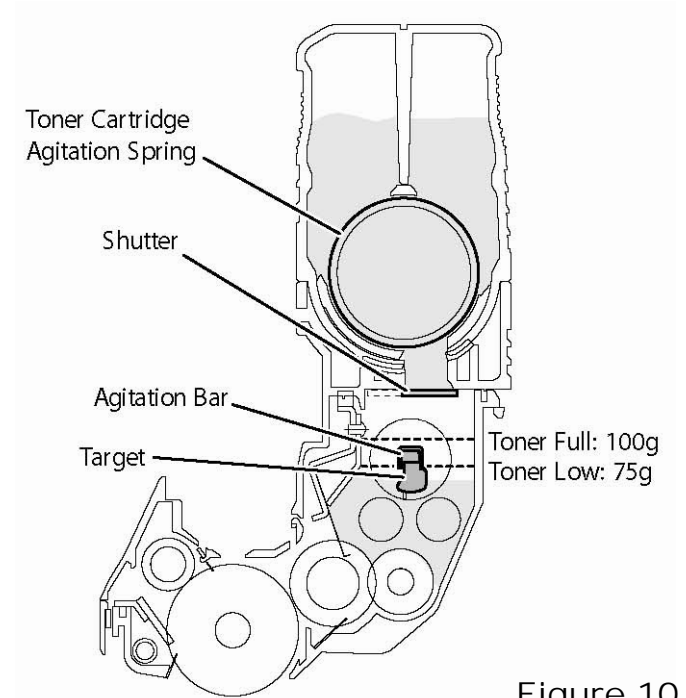

Figure 10

**Required Tools**

- Toner approved vacuum.
- A small (Jewelers) Common screw driver
- #1 Phillips head screwdriver
- Needle nose pliers



### Required Supplies

Phaser 7400 toner (Correct color for drum and tube!)  
New Wiper Blade  
New OPC Drum  
Sealing Strip  
Shipping locks  
Replacement chip for toner tube  
Replacement fuse for drum unit  
Drum lubricant  
PCR Cleaner  
Conductive grease

### Toner Cartridge

- 1) Clean the exterior of the cartridge.
- 2) With a small jewelers screwdriver. Carefully pry out the fill plug, and vacuum the hopper clean. See **Figure 11**



Figure 11

- 3) Carefully peel up the part number label off the handle side of the tube. See **Figure 12**

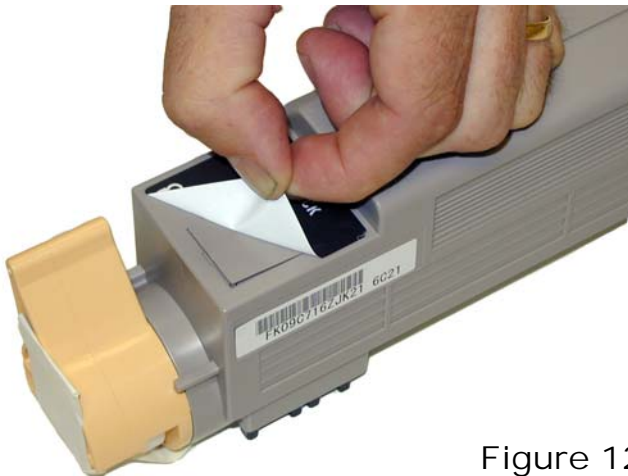

Figure 12

- 4) Remove chip cover with a small Jewelers screwdriver. See **Figure 13**



Figure 13

- 5) Replace the chip (Be careful to use the correct color chip!), cover and label. See **Figures 14 & 15**



Figure 14



Figure 15

6) Place a tape seal across the bottom of the tube. See **Figure 16**



Figure 16

7) Fill the hopper with the correct color toner, and replace the fill plug. See **Figures 17 & 18**. The toner tube is finished!



Figure 17



Figure 18

**Drum Unit**

8) On the front edge of the cartridge, release the two large plastic tabs, and two small tabs on the side of the cartridge. (One on each side), Remove the cover. See **Figures 19, 20, 21 & 22**



Figure 19



Figure 22

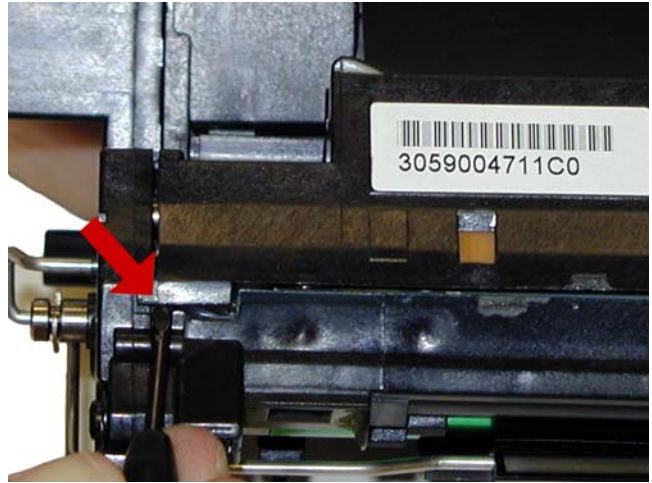

Figure 20

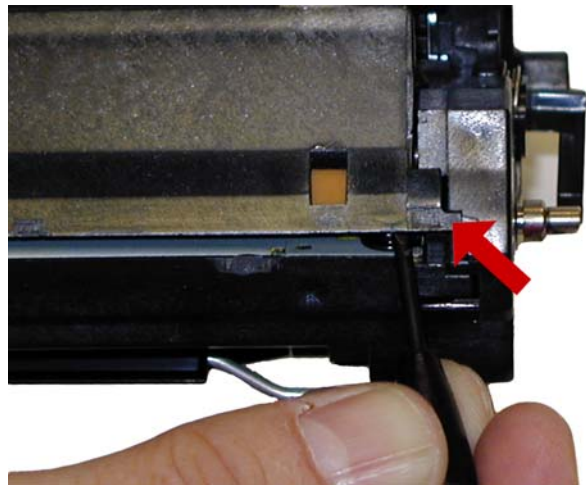

Figure 21



9) On the right (Label) side of the cartridge, remove the three screws from the end cap. See **Figure 23**

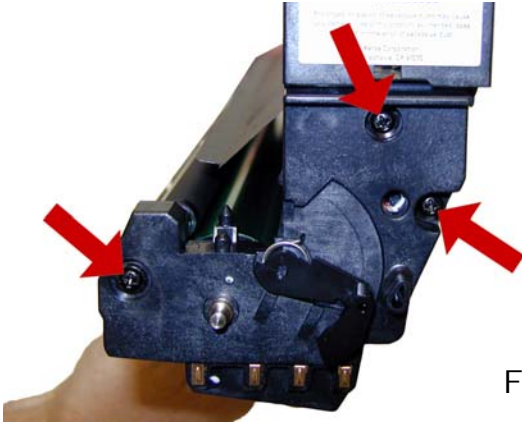

Figure 23

10) Remove the drum cover arm from the left (non-label) side of the cartridge. **Figure 24**

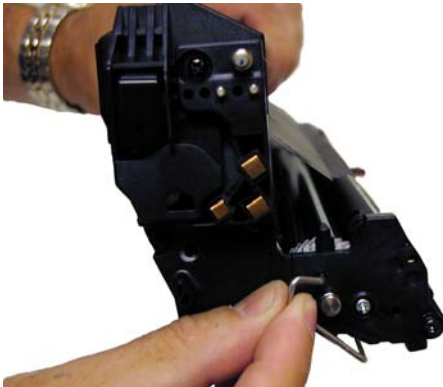

Figure 24

Note that the rest of the drum cover assembly is built inside the right end cap. The end cap, drum axle and drum cover will all be removed as one unit. There is no reason for these assemblies to be taken apart further. Put a piece of tape across the drum cover arm so that it does not come loose and you should not have any problems with this assembly.

11) Slowly start to remove the right side end cap. Do not fully remove it yet as many parts will now come loose. See **Figure 25**.

12) Remove the PCR by sliding it over to the right and lifting out. Be careful not to lose the PCR holder and springs. They may come loose. See **Figure 26**

13) Remove the side screw and waste chamber. This is done after the left side posts are free from the end cap, then turn the chamber up and lift out. See **Figures 27, 28, 29 and 30**

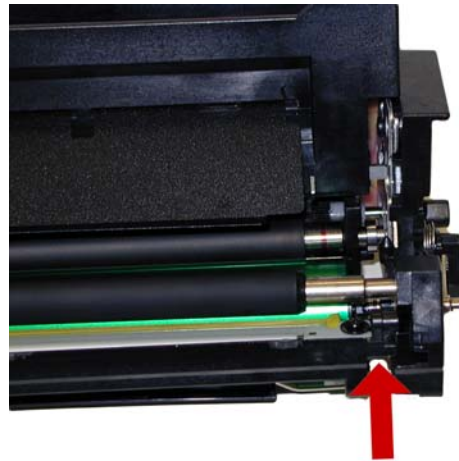

Figure 25



Figure 26

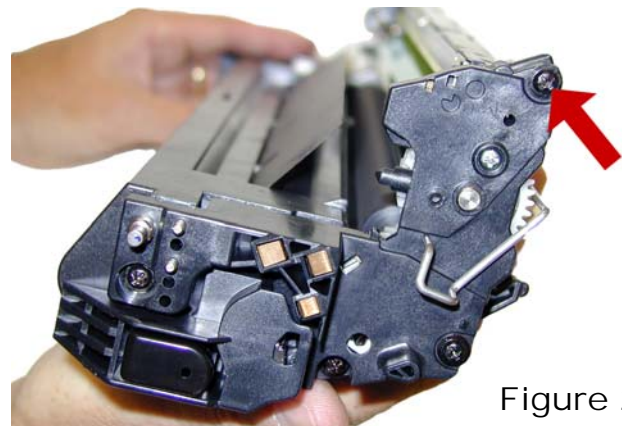

Figure 27



Figure 28

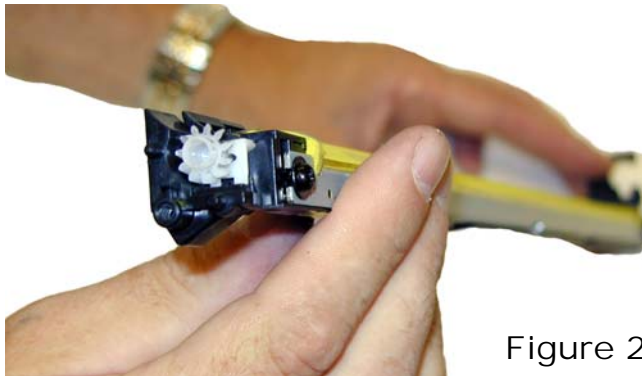

Figure 29

16) Remove the two screws from the inside of the toner hopper. See **Figure 33**



Figure 33

17) On the left (Non-Label) side, remove the 3 remaining black screws. The single silver screw does not have to be removed. See **Figure 34**



Figure 30

14) Slide the Right end cap completely off. The drum, drum axle, and drum cover will come with it. See **Figure 31**

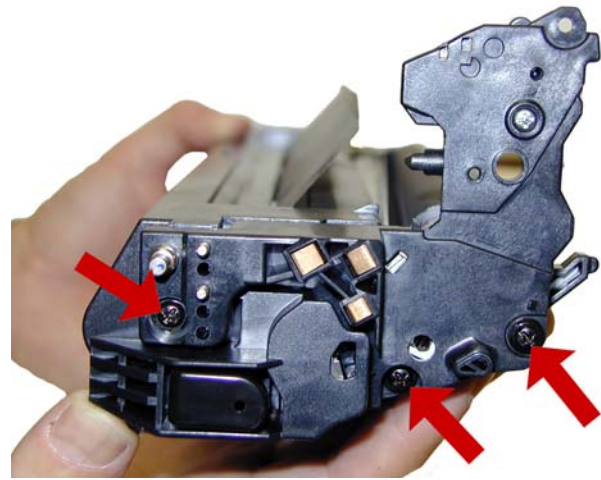

Figure 34



Figure 31

18) Lift up on the front edge of the toner hopper; release the three tabs from the back. Remove the hopper. See **Figures 35 & 36**

15) Remove the drum from the axle. See **Figure 32**

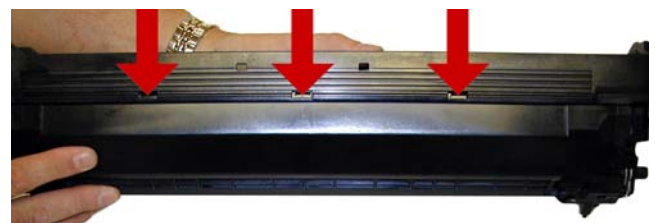

Figure 35



Figure 32



Figure 36

19) Remove the end cap. Note the fuse and flat washer on the metal plate. The fuse needs to be replaced before the cartridge is re-assembled. (later step). See **Figure 37**

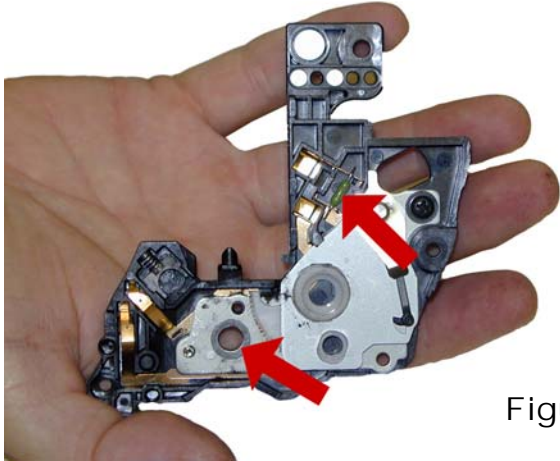

Figure 37

20) Remove the bearing from the developer roller shaft. See **Figure 38**.

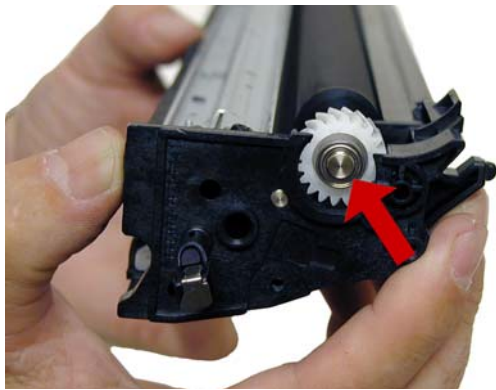

Figure 38

21) Press in on the gear side of the developer roller shaft and lift the roller up and out of the cartridge. See **Figures 39 & 40**



Figure 39



Figure 40

22) Remove the two screws on the doctor blade. Carefully remove the blade. See **Figures 41 & 42**



Figure 41



Figure 42

23) Clean out all remaining toner from the auger and supply roller. See **Figure 43**.



Figure 43

24) There is no need to remove the gear end cap, just make sure the gears are free from excess toner. See **Figure 44**

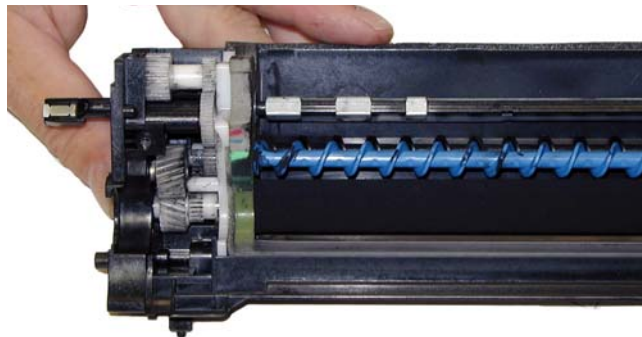

Figure 44

25) Install the doctor blade and two screws. Make sure you don't lose the side contact plate, it can come loose. See **Figures 45 & 46**



Figure 45



Figure 46

26) Slide the non gear side of the developer roller into the slot on the right side. Pull out gently on the gear end cap and drop the developer roller in place. **Figures 47 & 48**



Figure 47

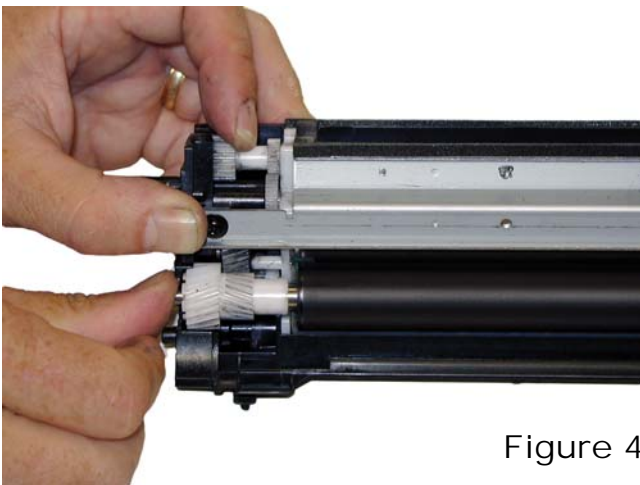

Figure 48

27) Install the bearing onto the gear side of the developer roller shaft. See **Figure 49**

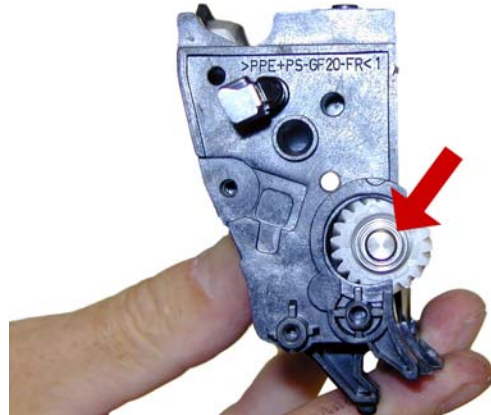

Figure 49

28) Change the fuse in the left end cap. The fuse just snaps in and out, no soldering needed. Make sure the bushing and small gear is sitting properly. See **Figure 50**



Figure 50

29) Install the left end cap and two black screws as shown. See **Figure 51**

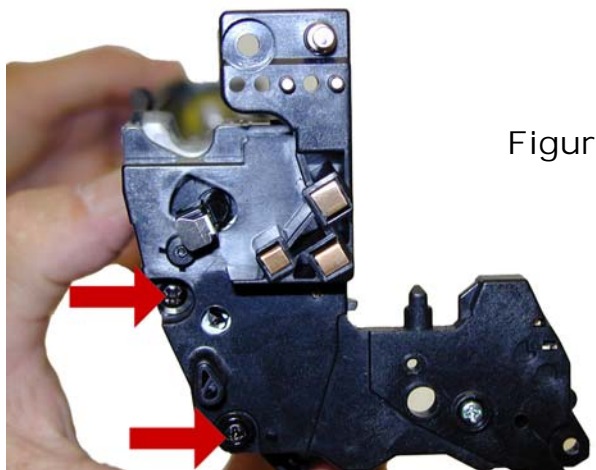

Figure 51

30) If the foam seal came loose, replace it now. You may have to condense the seal a little in order for it to fit properly. See **Figure 52**

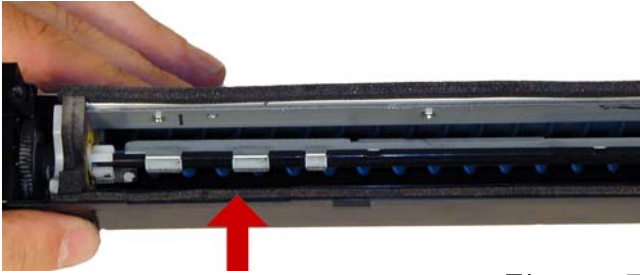

Figure 52

31) Install the toner hopper and two inside screws. Make sure the three tabs are locked in place. See **Figure 53**.

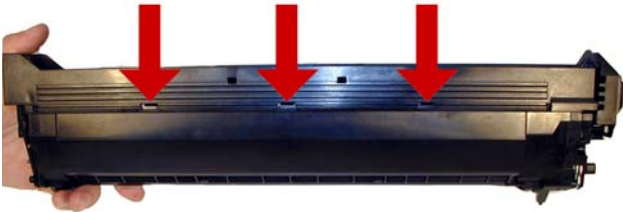

Figure 53



32) Install a black screw into the end cap/toner hopper. See **Figure 54**

Figure 54

33) Slide a new drum on to the drum axle shaft. See **Figure 55**



Figure 55

34) Partially install the right end cap/drum/drum cover assembly. See **Figure 56**



Figure 56

35) Install the PCR into its holders. See **Figure 57**



Figure 57

36) Take the waste chamber and remove the 2 screws from the wiper blade. Remove the blade. See **Figure 58**



Figure 58

37) Clean out all toner. Be careful not to damage the spring auger and felt seal. See **Figure 59**



Figure 59

38) Coat the new wiper blade with your preferred lubricant and install into the chamber. Install the two screws. See **Figure 60**



Figure 60

39) Install the waste chamber. Install the left side tabs first. See **Figure 61**

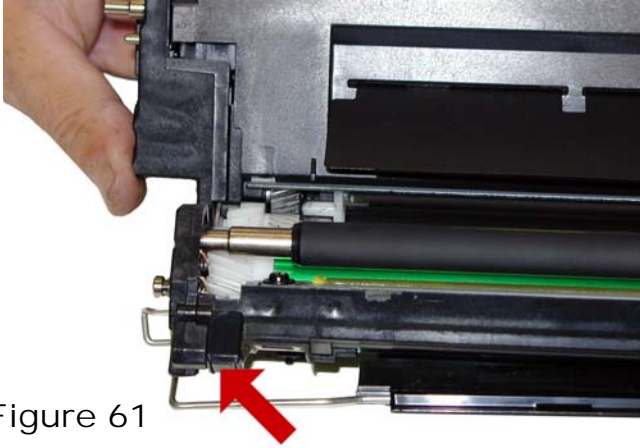

Figure 61

40) Install the right side end cap the rest of the way. Make sure it seats properly. See **Figure 62**

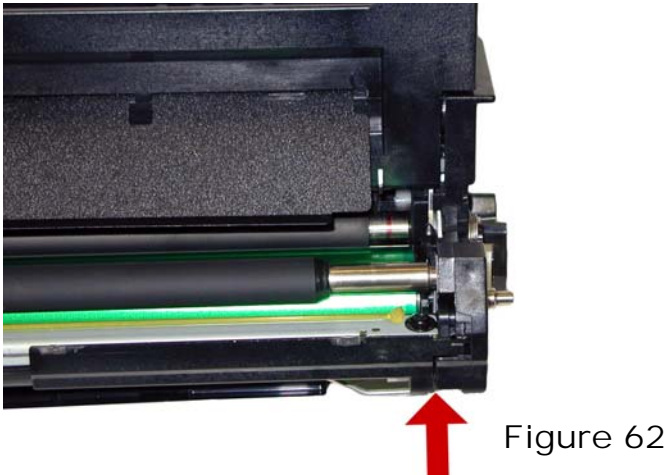

Figure 62

41) Install the two black screws to hold the waste chamber in place. One on each side. See **Figures 63 & 64**

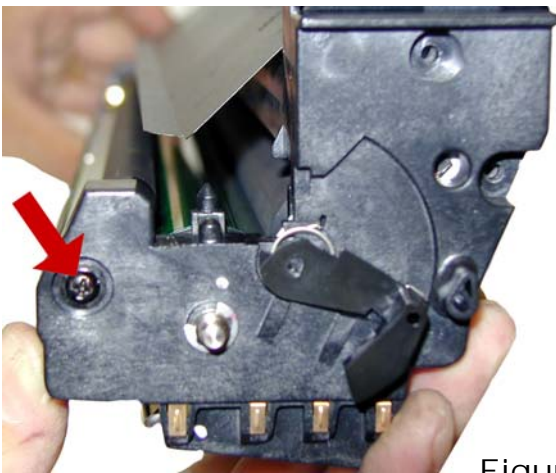

Figure 63

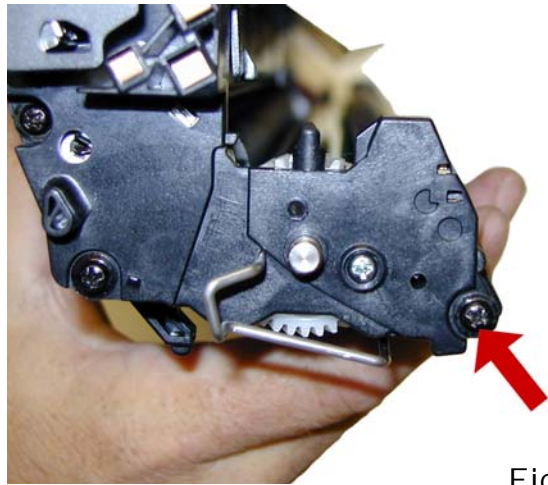

Figure 64

42) Install the left side of the drum cover bar. Test the cover with the arm on the right side to make sure it works. See **Figures 65 & 66**

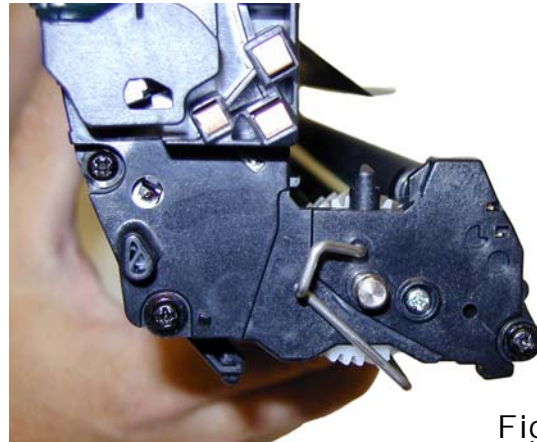

Figure 65



Figure 66

43) Install the three remaining black screws (2 on one side, one on the other). See **Figures 67 & 68**

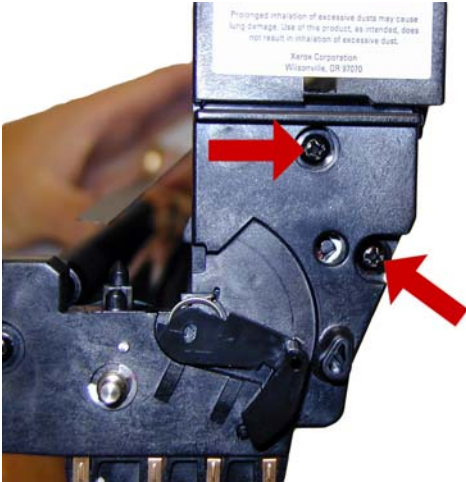

Figure 67

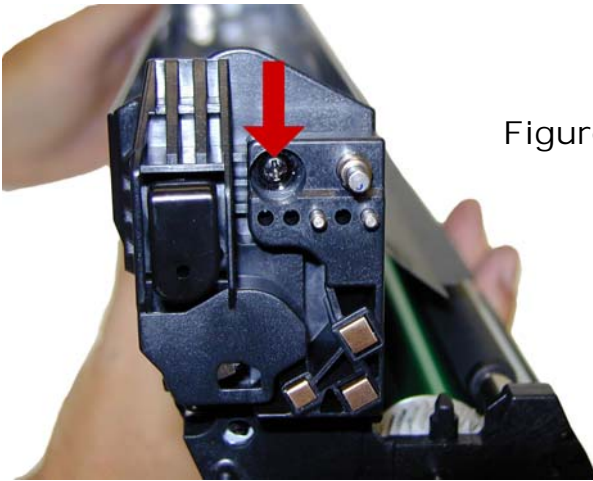

Figure 68

44) Install the PCR cover by rolling the top of the cover so the back tab locks in place. Roll the cover down until the front two tabs lock. See **Figure 69**

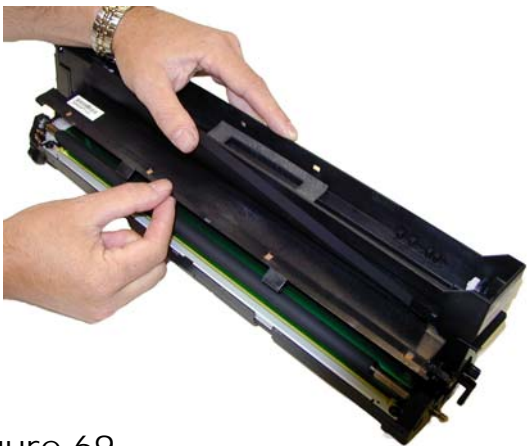

Figure 69

45) Install the toner and shipping locks. See **Figure 70**



Figure 70

Remember that new drum units come complete with toner already installed inside the cartridge. (Thus the need for the toner hopper seal in the drum unit. Because of this, you must include a toner tube with every drum cartridge. (Make sure it's the correct color!)

**Repetitive Defect Chart:**

Transfer Belt	706 mm
Fuser Belt	124 mm
Supply Roller	102 mm
OPC Drum	94 mm
Heat Fuser Roller	87.3 mm
Developer roller	49 mm
PCR	37.4 mm

It is also possible that dirty drum unit contacts can cause an issue, See **Figure 71** to see the location of the drum unit contacts

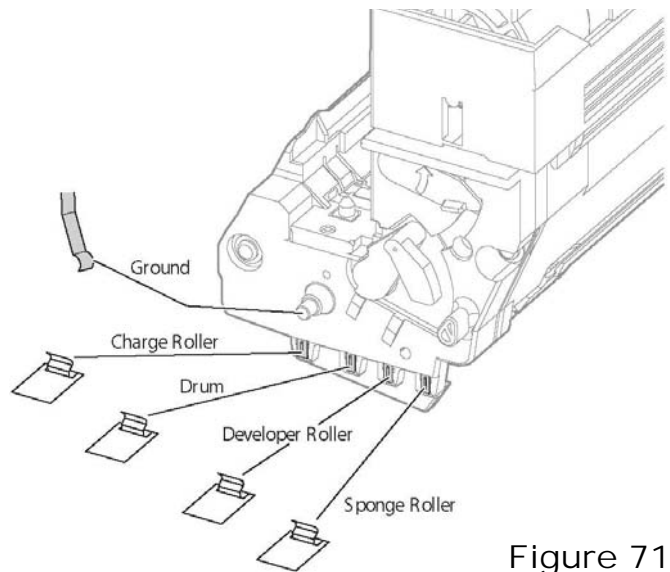

Figure 71

## Printing Test Pages

On the control panel, Select INFORMATION, Press OK  
Select INFORMATION PAGES, Press OK  
Select CONFIGURATION PAGES or SUPPLIES  
USAGE PAGE, Press OK

For Sample pages:

On the control panel, Select INFORMATION, Press OK  
Select SAMPLE PAGES, Press OK  
Select the color page and press OK

## Common Error Codes

There are hundreds of different 2 or 3 digit error codes.  
Too many to list here, but I have included some of the  
more common failures.

- T1 Upper fuser failure
- T2 Lower fuser failure
- T29 Temperature sensor bad
- T30 Humidity sensor bad
- U18 Yellow LED failure
- U19 Magenta LED Failure
- U20 Cyan LED Failure
- U21 Black LED Failure
- U26 Yellow drum failure. Drum out of position (Up/  
Down)
- U27 Magenta drum failure. Drum out of position (Up/  
Down)
- U28 Cyan drum failure. Drum out of position (Up/  
Down)
- U29 Black drum failure. Drum out of position (Up/  
Down)
- W18 Cyan imaging unit fuse cut error. The printer  
detected a new fuse (Drum unit) but the fuse did  
not blow (cut)
- W19 Magenta imaging unit fuse cut error. The printer  
detected a new fuse (Drum unit) but the fuse did  
not blow (cut)
- W20 Yellow imaging unit fuse cut error. The printer  
detected a new fuse (Drum unit) but the fuse did  
not blow (cut)
- W21 Black imaging unit fuse cut error. The printer  
detected a new fuse (Drum unit) but the fuse did  
not blow (cut)
- 940 Waste toner auger rotation failure.
- 941 CM Toner supply failure Toner sensor failure  
with Cyan or Magenta toner
- 942 YK Toner supply failure Toner sensor failure  
with Yellow or Black toner

